



Planning documents for **BASWA DTG acoustic systems**

DTG Prime Base

DTG Prime Fine

DTG Prime Top

DTG Prime Casual

Content

System description	3
The BASWA DTG acoustic systems	8
<hr/>	
BASWA DTG Prime Base	9
BASWA DTG Prime Fine	9
BASWA DTG Prime Top	10
BASWA DTG Prime Casual	10
Sound absorption BASWA DTG acoustic systems	11
Installation times	13
System components and consumption data	14
Preparation and planning	15
<hr/>	
Requirements and prerequisites	16
Installation planning	17
Substructure	18
Scheme substructure	20
Installation scheme / incidence of light, Screwing	21
Building and room conditions	22
Scaffolds	26
Subsequent work, Repairs	27
Storage	28
Dew point	29
BASWA Colours	30
Light reflection of BASWA acoustic coatings	31
Surface structures and effects	32
Protection, cleaning, maintenance and refurbishment	33
Common construction details	38
<hr/>	
Common construction details, Wall connection	39
Spotlights, Ceiling lights	41
Installations with BASWA installation platforms DTG, Ventilation outlet	42
Service openings	43
Building expansion joints	44
Design corners	46
Ceiling canopy	47
Legal notice	48
General Terms and Conditions	49

System description

General

System properties:

- Very good sound absorption up to class A, α_w 0,90 / NRC 0,85
- Fire classification: A2-s1, d0 (DIN EN 13501-1)
- Longitudinal sound insulation $D_{n,f,w}$ = 39 dB (DIN EN ISO 10848-2)
- Sound reduction index R_w = 8 dB (DIN EN ISO 10140)
- Impact sound reduction L_w = 11 dB (DIN EN ISO 10140)
- Indoor climate: Very low emission → French VOC regulation: A+
- Suitable for damp rooms up to 90% rel. humidity
- Fibre- and solvent-free
- Recyclable
- seamlessly up to 200 m²
- System thickness 40 mm
- 2 layer system
- Unlimited colour selection (RAL, NCS, etc.) for BASWA Base, Fine and Top
- BASWA Casual: colours on request
- Final layer from fine-textured (BASWA Casual) to ultra-smooth (BASWA Top)

Benefits:

- Sustainability: high proportion of recycled materials (up to 85%)
- Installation possible without circumferential open shadow joints (project-specific)
- Extensive cleaning and renovation concept
- No filling of joints
- High surface quality standard
- Easy, safe installation directly on metal substructures according to EN 13964
- Very low system weight of only approx. 5.5–6.0 kg / m² (without substructure)
- BASWA system accessories can be used
- Materials that are harmless to health
- Optics: high whiteness / L-value: up to 92 %
- CE mark

Suitable for mounting jointless surfaces (up to the maximum permissible size of the substructure), such as:

- Horizontal and vertical straight ceilings
- Walls outside the area at risk of impact, above 1,80 m height
- Simple concave curves (barrel vault): Radius >0,60 m Radius
- Simple convex curves (barrel vault): Radius >0,60 m Radius

With acoustic panels cut into every 5 cm on the view side and double layer of BASWA Prime.

Without cutting into the acoustic panels: radius >20 m.

The BASWA DTG acoustic system is a highly sound-absorbing, directly suspended, seamless acoustic system.

The BASWA DTG acoustic panels with airtight coating on the back are mounted directly on a metal substructure (according to EN 13964 with nonius suspension) with the specially developed BASWA Disc DTG insulation discs and the phosphated BASWA drywall screws, glued on the front side all around with BASWA Fix DTG and on the back side at the longitudinal joints with SIGA Sicrall adhesive tape. Finally, the surface is coated with BASWA Prime as a base layer and BASWA Base/Fine/Top or BASWA Casual seamless.

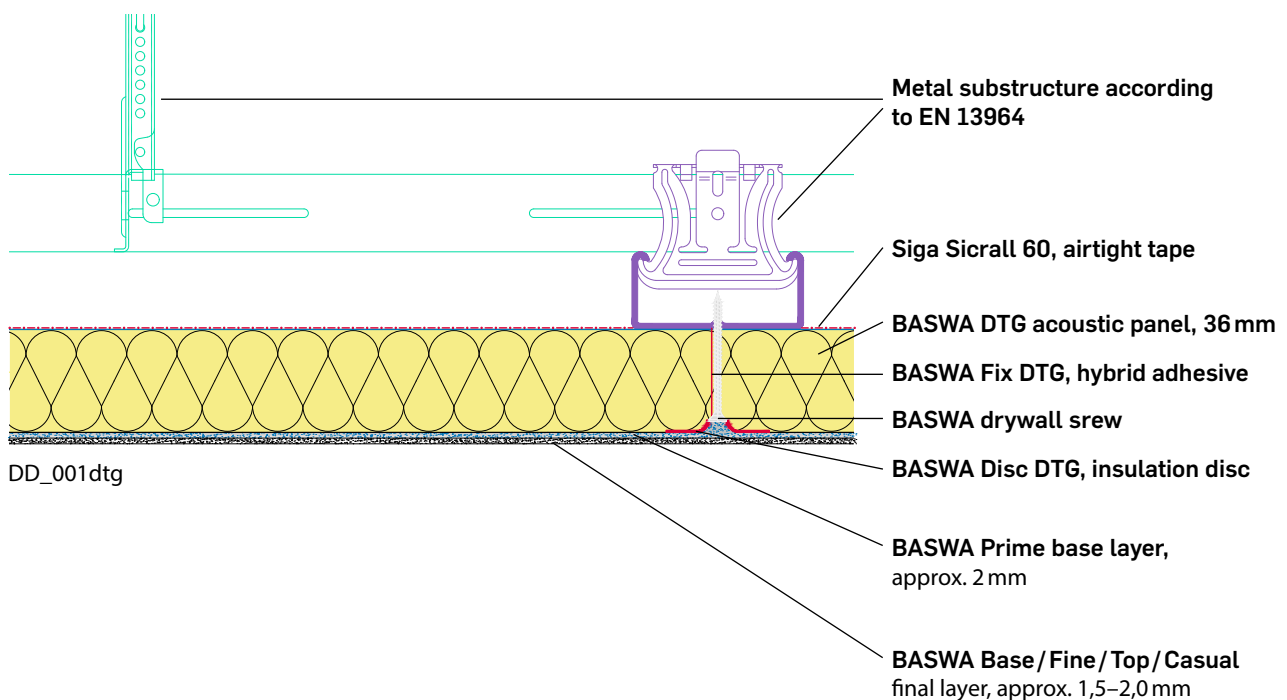

Overview BASWA DTG system types

BASWA DTG acoustic systems are only installed directly onto a metal substructure in accordance with EN 13964.

The base layer for all BASWA DTG system types is BASWA Prime.

Variations of the final layer are:

- **BASWA Base** granular surface structure (grain size 0,7 mm)
- **BASWA Fine** smooth, medium grain surface structure (grain size 0,5 mm)
- **BASWA Top** ultra-smooth surface structure (grain size 0,3 mm)
- **BASWA Casual** lightly textured surface (grain size 0,3–0,5 mm)

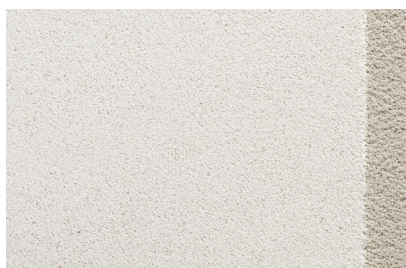

BASWA DTG Prime Base

Base layer BASWA Prime
Final layer **BASWA Base**

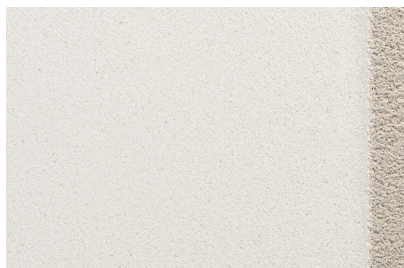

BASWA DTG Prime Fine

Base layer BASWA Prime
Final layer **BASWA Fine**

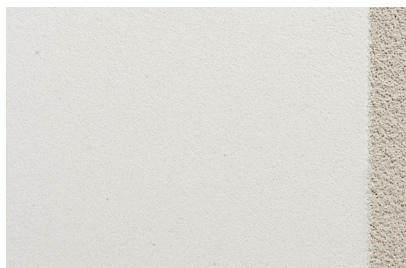

BASWA DTG Prime Top

Base layer BASWA Prime
Final layer **BASWA Top**

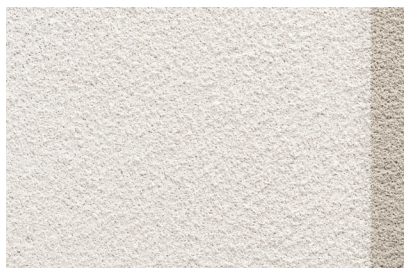

BASWA DTG Prime Casual

Base layer BASWA Prime
Final layer **BASWA Casual**

Reverberation time

Wherever people spend time indoors, they speak and sing, work and produce. People seek relaxation and recreation and should find peace and sleep. In this context, the architecture and consequently the design, but also the health, the comfort and especially the cosiness in buildings are decisive factors that have to do with the room acoustics and their quality. Room quality is thus decisively defined by room sound, speech intelligibility, noise, reverberation time and sound distribution as well as noise reduction. The result of a reverberation time that is optimally adjusted to the needs of a room is thus reflected in many areas of daily life.

A large number of independent investigations and studies confirm that poor room acoustics at the workplace, at home or in public areas with too much noise and poor speech intelligibility can demonstrably lead to increased stress, high blood pressure, concentration problems, reduced productivity, increased pulse and fatigue and even trigger various illnesses.

Adapted and perfectly optimised room acoustics by BASWA acoustic systems create peace, cosiness and comfort through high sound absorption.

In this way, BASWA acoustic systems can make a significant contribution to preventing the possible consequences mentioned and massively increase the quality of life.

Sound insulation

The impenetrability of walls and ceilings to the outside, to neighbours and within the family is increasingly seen as a high good.

Protection against disturbing noise thus significantly determines the well-being and satisfaction of the users in a building. Good sound insulation has a positive influence on the ability to concentrate, the protection of confidentiality, the need for quiet, living comfort and health.

To explain: sound consists of mechanical vibrations that behave differently in different materials. The two essential physical parameters of sound are frequency, measured in vibrations per second (Hz) and loudness (sound pressure, sound level), measured in decibels (dB).

BASWA DTG acoustic systems not only reduce reverberation times in buildings, but also actively contribute to sound insulation (airborne sound and impact sound reduction) in rooms and buildings and thus to structural sound insulation as an added value.

- Longitudinal sound insulation $D_{n,f,w} = 39$ dB (DIN EN ISO 10848-2)
- Improvement of airborne sound insulation on a solid ceiling (140 mm reinforced concrete ceiling): $R_w = 8$ dB (DIN EN ISO 10140)
- Impact sound reduction (140 mm reinforced concrete ceiling)
 $L_w = 11$ dB (DIN EN ISO 10140)

Note: A sound reduction of 6 dB corresponds physically to a halving of the sound level, whereas a difference of approx. 9–10 dB is perceived by humans as a halving or doubling.

The BASWA DTG acoustic systems

BASWA DTG Prime Base

System profile

- Sound absorption up to α_W : 0,90
- 2 layer system
- Smooth, seamless surface
- Grain size of the final layer: 0,7 mm
- Standard colour ~ NCS S 0500-N
- Whiteness / L-value: up to 90%
- Surface finish Standard <to Q3>
- System weight: approx. 6,0 kg/m²



BASWA DTG Prime Fine

System profile

- Sound absorption up to α_W : 0,80
- 2 layer system
- Very smooth, seamless surface
- Grain size of the final layer: 0,5 mm
- Standard colour ~ NCS S 0500-N
- Whiteness / L-value: up to 91%
- Surface finish Standard <to Q3>
- System weight: approx. 5,8 kg/m²



BASWA DTG Prime Top

System profile

- Sound absorption up to α_W : 0,70
- 2 layer system
- Ultra-smooth, seamless surface
- Grain size of the final layer: 0,3 mm
- Standard colour ~ NCS S 0500-N
- Whiteness / L-value: up to 92 %
- Surface finish Standard <to Q3>
- System weight: approx. 5,7 kg/m²



BASWA DTG Prime Casual

System profile

- Sound absorption up to α_W : 0,70
- 2 layer system
- Finely structured, seamless surface
- Grain size of the final layer: 0,3 – 0,5 mm
- Standard colour ~ NCS S 0500-N
- Other colours on request
- Whiteness / L-value: up to 90 %
- Surface finish Standard <to Q3>
- System weight: approx. 5,6 kg/m²



Sound absorption BASWA DTG acoustic systems



Sound absorption coefficients α_p (practical) according to ISO standard DIN EN ISO 11654

BASWA DTG Prime Base

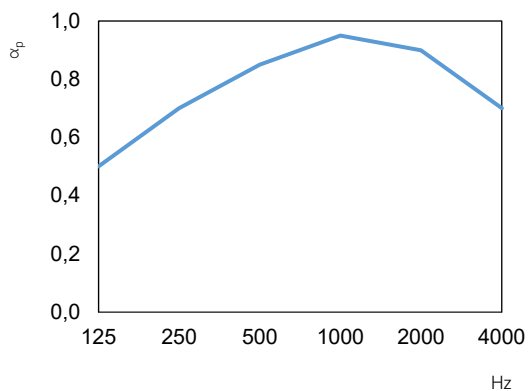

BASWA DTG Prime Fine

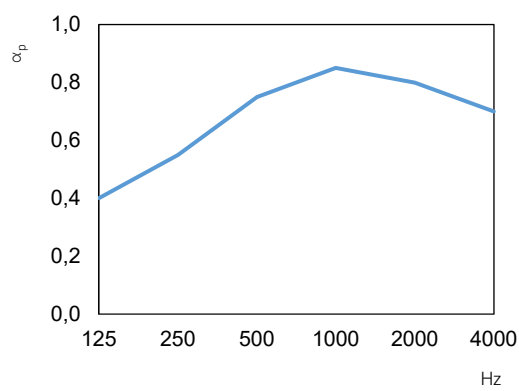

BASWA DTG Prime Top

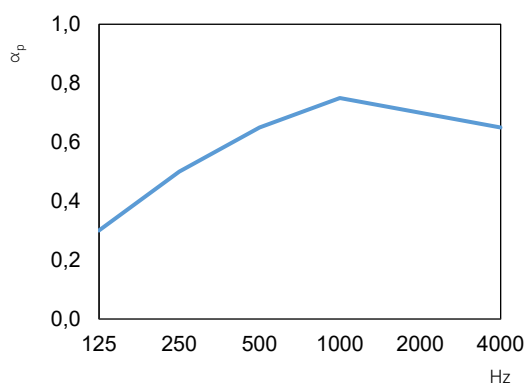

BASWA DTG Prime Casual

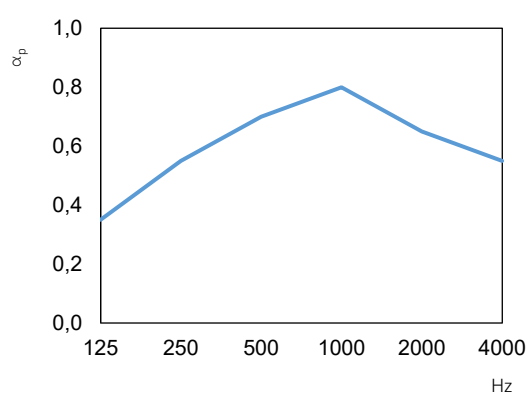

Overview sound absorption BASWA DTG acoustic systems

System	DTG Prime Base		DTG Prime Fine		DTG Prime Top		DTG Prime Casual	
α_w	0,90		0,80		0,70		0,70	
NRC	0,85		0,75		0,65		0,70	
Hz	α_p	α_s	α_p	α_s	α_p	α_s	α_p	α_s
100	0,50	0,43	0,40	0,32	0,30	0,38	0,35	0,43
125		0,52		0,46		0,17		0,21
160		0,61		0,40		0,39		0,40
200	0,70	0,62	0,55	0,52	0,50	0,47	0,55	0,51
250		0,71		0,58		0,49		0,53
315		0,84		0,61		0,56		0,61
400	0,85	0,88	0,75	0,71	0,65	0,63	0,70	0,66
500		0,92		0,73		0,65		0,69
630		0,79		0,74		0,69		0,72
800	0,95	0,92	0,85	0,79	0,75	0,72	0,80	0,74
1000		0,94		0,85		0,80		0,85
1250		0,95		0,84		0,75		0,74
1600	0,90	0,94	0,80	0,84	0,70	0,73	0,65	0,67
2000		0,90		0,82		0,73		0,67
2500		0,88		0,79		0,70		0,62
3150	0,90	0,92	0,70	0,76	0,65	0,71	0,55	0,58
4000		0,89		0,71		0,65		0,53
5000		0,85		0,63		0,62		0,51

Attention! When using coloured BASWA acoustic coatings and decorative designs (e.g BASWA Textures), the specified sound absorption values may change slightly in individual cases.

Installation times

The specified installation times refer to a team of 3 to 4 people and an area of approx. 80–100 m². The drying times refer to the room climatic conditions: 20°C room temperature / 50% relative humidity.

Attention! It is essential to allow each work step to dry completely! Complete drying, especially of the BASWA Prime base coat, must be checked before applying the final coat.

BASWA DTG Prime Base/Fine/Top

days	1	2	3	4	5	6	7
Mounting BASWA DTG panels	●						
Sand surface flat		●					
Apply BASWA Prime base coat		●					
BASWA Prime flat sanding					●		
Apply BASWA Base, Fine, Top					●		
Follow up work							●

BASWA DTG Prime Casual

days	1	2	3	4	5	6	7	8	9
Mounting BASWA DTG panels	●								
Sand surface flat		●							
Apply BASWA Prime base coat		●							
BASWA Prime flat sanding					●				
BASWA Casual 1 spray application					●				
BASWA Casual 2 spray application							●		
Follow up work									●

Attention! With coloured BASWA Casual and other local conditions, a third spray application may be necessary to completely cover the base coat. Note increased material consumption and extended installation time of approx. 1 day!

System components and consumption data per m² from substructure

BASWA DTG System Components	Consumption per m ²	Range per unit
BASWA DTG Acoustic panel	1,38 Pcs.	0,72 m ²
SIGA Sicrall 60, Airtight tape	1,7 m	23,0 m ²
BASWA Fix DTG, Hybrid adhesive	67 ml	4,5 m ²
BASWA Drywall screws	12 – 15 Pcs.	33 – 41 m ²
BASWA Disc DTG, Insulation disc	12 – 15 Pcs.	16,5 – 21,0 m ²
BASWA Prime, base layer	2,4 – 2,6 kg	7,3 – 7,8 m ² (50 L bucket)
BASWA Base, final layer	3,5 – 4,0 kg	6,2 – 7,0 m ²
BASWA Fine, final layer	3,0 kg	8,0 m ²
BASWA Top, final layer	2,3 kg	10,5 m ²
BASWA Casual, final layer Standard White	1,6 – 2,4 kg (2 – 3 layers)	6,5 – 10 m ²
BASWA Casual, final layer coloured	2,4 kg (3 layers)	6,5 m ²

The material consumption depends, among other things, on the application, substrate and consistency.

The consumption values given can only serve as a guide.

Exact consumption values must be determined according to the project if necessary. Values do not include wastage.

Preparation and planning

Requirements and prerequisites

General

Correct planning, careful site preparation and execution of the work under optimum installation conditions are necessary to guarantee the surface quality and service life of a BASWA DTG acoustic system.

In order to ensure the acoustic and aesthetic quality as well as the longevity of the BASWA surfaces, BASWA systems are exclusively installed by trained and certified companies. The experience of the executing team, a suitable scaffolding and adherence to the installation guidelines are essential prerequisites for the installation of the BASWA System.

Standards and recommendations

The current guidelines of the company BASWA acoustic AG must be observed for both types of work. The agreed terms and conditions as outlined in the planning documents, installation guidelines, and the general terms and conditions of BASWA acoustic AG take effect on the date of the contract.

Certification of installing companies

In order to qualify for the installation of BASWA acoustic systems, it is necessary to attend a certification course. BASWA acoustic AG products can only be purchased from certified companies.

Companies that are about to carry out a project with BASWA acoustic systems should attend an installation course at the respective BASWA company location 4–6 weeks before the start of the project. Information about the courses on offer can be obtained from the regional contact person at BASWA acoustic AG. Upon completion of the training, the course participants and the company receive a certificate which identifies them as a certified BASWA installer. On request, BASWA provides architects and planners with a list of certified and experienced companies.

Companies that do not carry out any projects for 2 years lose certification. However, the company is free to attend another certification course.

Installation planning

Fundamental planning information

- To avoid uncontrolled negative pressure areas, cavities on adjacent walls must be closed.
- BASWA acoustic AG generally recommends planning a pressure equalisation between the ceiling cavity and the used room by means of a circumferential open shadow gap. The size of the shadow gap must be at least 0.8% of the ceiling area. In principle, it is recommended to plan a circumferential shadow gap of at least 2 cm.
 - Area $\leq 100 \text{ m}^2$ = Circumferential shadow gap approx. 20 mm but at least 0.8% of the ceiling area).
 - Area $> 100 \text{ m}^2$ = Circumferential shadow gap approx. 25 mm, but at least 0.8% of the ceiling area).
- The BASWA DTG acoustic panels must be glued together airtight and joint-tight all around using the BASWA Fix DTG adhesive!
- In addition, **all** longitudinal joints must be sealed airtight with Siga Sicrall 60 adhesive tape on the back of the BASWA DTG acoustic panels.
- As a general rule, ceiling installations should be carried out using BASWA installation platforms wherever possible.
- Rigid or force-fit connections to adjacent building components must be avoided and are not permitted.
- The installation of BASWA acoustic systems, in particular the application of the final coating, is to be carried out in the last phase of the interior construction if possible.

Substructure

The seamless BASWA DTG acoustic systems are mounted on a pressure-resistant metal substructure which is anchored in the ceiling subfloor.

Suspension

- Commercially available nonius hangers or pressure-resistant direct hangers (U-hangers) are to be used for suspension.
- If the load-bearing capacity of the raw ceiling in old buildings, for example, is not sufficient to take the loads of the BASWA DTG acoustic ceilings, wide span beams (with double-T cross-section) must be planned and used professionally. These are also used if the distances between the load-bearing components are too large.
- The anchoring of the substructure in the ceiling subfloor is carried out according to the static requirements of the structural situation on site.
- Anchors and screws are to be selected according to the material and substrate as well as the loads to be applied.

Substructure

The substructure consists of a classic, compression-resistant CD construction according to EN 13964 with base and support grid.

- The distance between the base profiles is max. 1'250 mm with a suspension distance of max. 800 mm. The support grid is mounted at a distance of max. 400 mm.
- Both CD constructions are to be connected by means of cross connectors.
- Suspensions with quick-action springs or wire suspension are not permitted.
- The use of a UD edge profile in the plane of the base profile is possible.
- Movement joints of the building must be taken over constructively with the same movement possibility! Note: If movement joints are planned, the substructure must be adapted accordingly. Expansion or movement joints must be arranged for larger component surfaces.
 - Maximum seamless area: 200 m² (depending on building construction).
 - Maximum side length: 15 m (depending on building construction!). Maximum side length is to be defined project-specifically on site! Ceiling areas with DTG systems must generally be limited by movement joints every 15 m in both longitudinal and transverse direction).
- In case of expected movements of the shell construction (e.g. shrinkage, creep, variable traffic loads, controlled settlements), sliding ceiling and/or wall connections are to be carried out.
- Fixtures in the ceiling level must be planned in advance and adapted to the substructure.
- If the fine grating of the substructure is cut through by ceiling fixtures (e.g. BASWA inspection covers), it is imperative that additional changes are made.
- In damp rooms, it is mandatory to install a corrosion-protected substructure according to EN 13964!

Attention! BASWA acoustic AG strongly recommends purchasing and installing the individual components of the substructure in the system of a manufacturer!

Scheme substructure

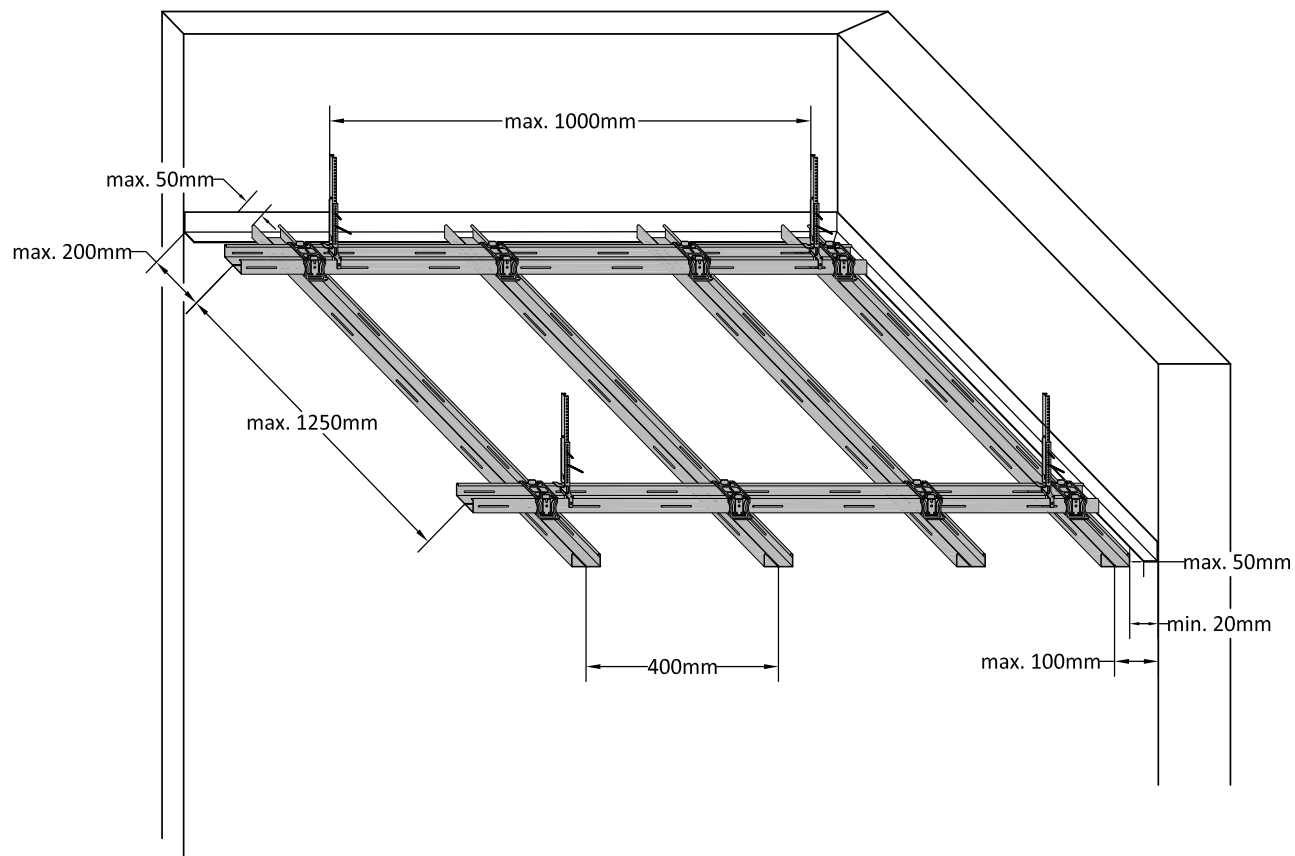

- Nonius hanger: distance ≤ 800 mm
- Base grid: distance ≤ 900 mm
- Fine grate: distance ≤ 400 mm

Installation scheme/incidence of light BASWA DTG acoustic panels

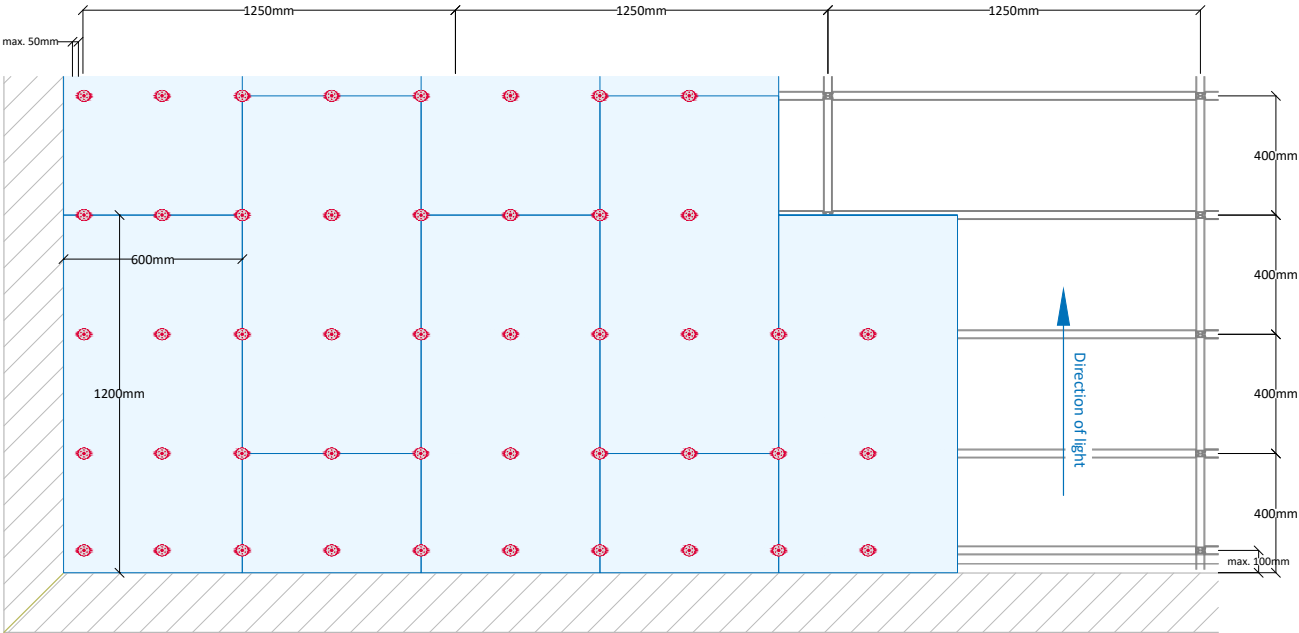

Screwing the BASWA DTG acoustic panels to the substructure

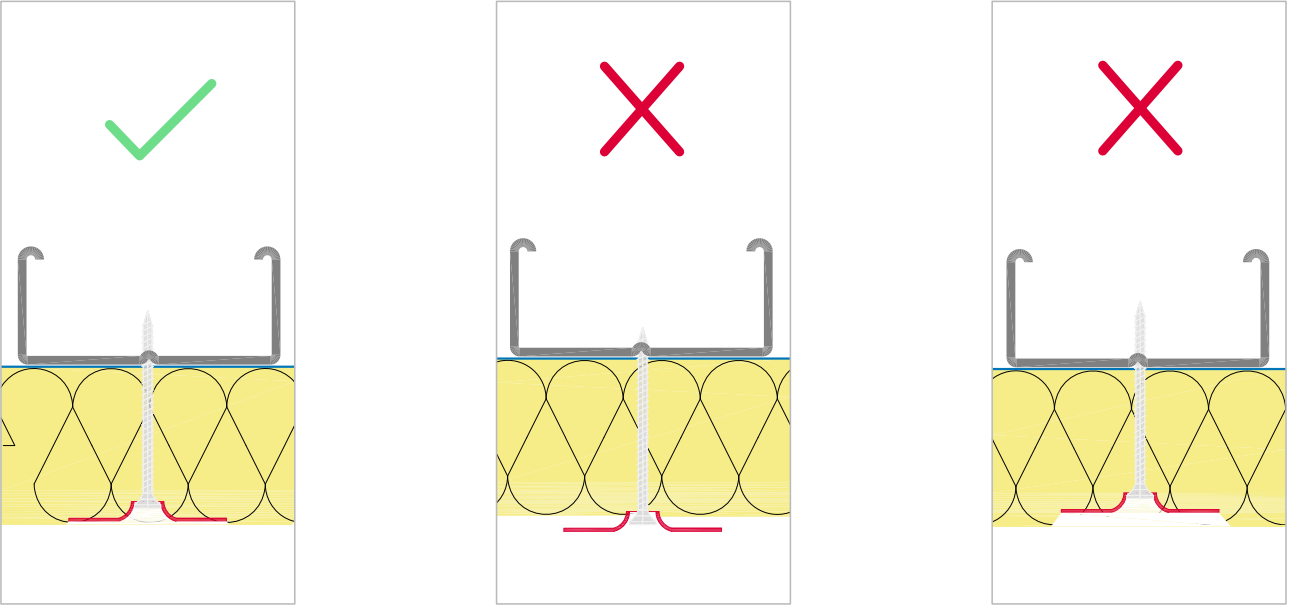

Building and room conditions

Installation

- Temperatures of at least 15°C to max. 30°C must be maintained during installation until complete drying.
- Avoid draughts during installation.
- During the drying time no temperature gradient of more than 10°C may occur!
- In case of high humidity in the building, the drying time will be prolonged! The use of gas heaters is not recommended. These usually increase the relative humidity, which considerably prolongs the drying time!

Building use

- Up to stress category B (SN EN 13964 for suspended ceilings) at 90% relative humidity and 30°C ($\pm 2^\circ\text{C}$).

Dew point

- If there are strong fluctuations in temperature and relative humidity, care must be taken to ensure that the dew point is not located on the surface or within the BASWA acoustic system.
- The design of the building insulation and the commissioning of air conditioning systems must be planned and controlled accordingly.
- The moisture caused by condensation in the room air can cause damage to the BASWA acoustic system.

Drying times, time planning and finish dates

The minimum drying times between the individual processing steps must be observed. These drying times refer to 20°C room temperature and 50% relative humidity. Cold and/or high humidity extend the drying times. Air fans with or without heating reduce the drying times so that a faster installation time can be guaranteed. Ensure that the substrate is completely dry before carrying out any further work.

Seamlessness

BASWA DTG acoustic systems do not require joints as a system, but the specific properties of the ceiling or wall surface, as well as the shape of the construction, material expansion, possible subsidence or deformation of the shell must be taken into account. Joints in the subfloor caused by the construction must be taken over in the BASWA DTG system structure.

The guidelines of the product suppliers of the selected substructure must be observed according to the regulations!

Application in damp rooms and weather-protected outdoor areas

- **Installation only with corrosion-protected support structure according to EN 13964!**
- Up to stress class B (SN EN 13964 for suspended ceilings) at 90% relative humidity and 30 °C (± 2 °C).
(No visual changes, such as discolouration, blistering, wavy surfaces, changes in thickness, etc.)

The use of BASWA DTG acoustic systems in special areas of application is subject to special requirements.

Substructure

The substructure must meet the requirements for damp rooms indoors (cf. DIN 18 168 T1 and T2, as well as DIN EN 13964-2014 Table 9 at least class C). In particular, a substructure with corrosion protection must be prepared. BASWA acoustic AG categorically rejects any liability for the substructure.

Installation note: In damp rooms, sufficient ventilation of the ceiling cavity and controlled ventilation (air conditioning) of the room are always recommended.

Additional surface protection

Furthermore, a subsequent surface hydrophobisation with BASWA Protect is recommended.

Climatic conditions/ dew point

(see Climatic building and room conditions, page 29)

Chemical exposure

The vapours and gases (chlorine, ozone, brine, etc.) usually found in such damp rooms (e.g. swimming pools) are compatible with the BASWA DTG acoustic system. Care must be taken that no solid or liquid precipitation or deposits form on the ceiling. These can lead to discolouration on the surface. Direct contact by splashing water must be prevented.

Fixtures

Fixtures, adjacent components and superstructures must meet the requirements that prevail in the corresponding wet rooms (corrosion resistance, cf. cited standards). No thermal bridges may be created by installations, extensions or superstructures, as these can lead to corrosion-related damage.

Side light conditions

It is not advisable to plan lateral illumination of the BASWA DTG surfaces with LED luminaires. Under the influence of the lateral LED light, the slightest traces of installation and irregularities become highly visible. It is therefore advisable to have a surface sampled in advance under original lighting.

Quality levels

Unless otherwise agreed, the standard surface quality is Q2. If increased requirements (Q3) are placed on the evenness of surfaces, this must be explicitly stated in the bill of quantities and contractually agreed.

Flatness and dimensional tolerances

In the case of increased requirements for surface quality 3, additional evenness tolerances must be agreed. These already apply to the preparation work of the substrate on which the BASWA acoustic systems are installed.

Scaffolds

In order to achieve the best possible surface quality, the coating installation are to be carried out with the aid of surface frameworks. This ensures an unhindered, continuous workflow, especially during the smoothing of the final layer.

The height difference between ceiling and surface scaffold must be adjusted to the body size of the installation team (optimum difference between scaffold and ceiling between 185 and 195 cm).

When installing the BASWA DTG Prime Casual system, it is possible to install rolling scaffolds instead of surface scaffolds under certain conditions. This depends on factors such as room size, accessibility, etc. in the room.

Watch your step! Wearing headgear during coating work can damage the freshly created surface!

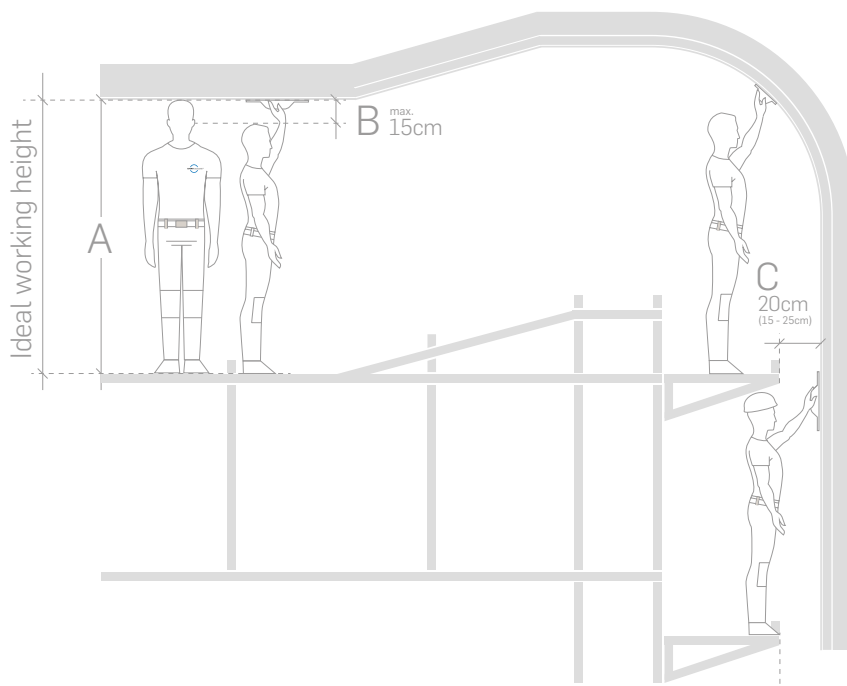

Wall scaffolds

When applying coating compounds to vertical surfaces, it is advisable to work on facade scaffolding constructions using scaffolding brackets. A settling in the middle of the surface leads to visible traces of installation. The distance between the surface and the scaffold bracket should be at least 15 cm, optimally 20–25 cm. The national safety regulations regarding maximum distances must be observed.

Temporary safety anchors in the wall construction should be avoided wherever possible.

Subsequent work

Subsequent installation work by other trades on BASWA system surfaces (e.g. installation of luminaires) must be carried out carefully and with clean gloves. All planners and craftsmen involved in the construction must be made aware of the consequential costs arising from subsequent damage or planning changes.

Repairs

BASWA DTG surfaces are partially repairable only to a limited extent (depending on the size and illumination of the repair areas). The repaired area usually has a slightly different structure and becomes visible under unfavourable light incidence. In case of larger damages, it is recommended to recoat the entire surface. Furthermore, it is advantageous to divide the surfaces into smaller areas by means of separation joints.

Storage

The BASWA products are delivered on pallets in EU format and should be stored correctly on the construction site or in the material warehouse until installation.

- Protect from weather and frost (air-conditioned containers if necessary).
- Acoustic panels must also be protected against dew formation (wetness).
- Temperature in storage room min. 5 °C max. 30 °C.
- Products must be protected from direct sunlight.

The expiry date of coating compounds and joint fillers is 12 months from production. BASWA products are provided with a batch number:

2 Year

04 Month

12 Day

2 Batch

Production date
= 12.04.2022

Dew point

When planning a BASWA DTG acoustic system adjacent to the outer shell of the building, the dew point must be calculated and checked in advance by a specialist planner (e.g. at the top floor / outside walls / balcony, terrace undersides / cold rooms, etc.).

If the dew point is within the BASWA acoustic system, the surface will change colour irregularly within a very short time due to condensation (increased dust adhesion to the moist coating surface).

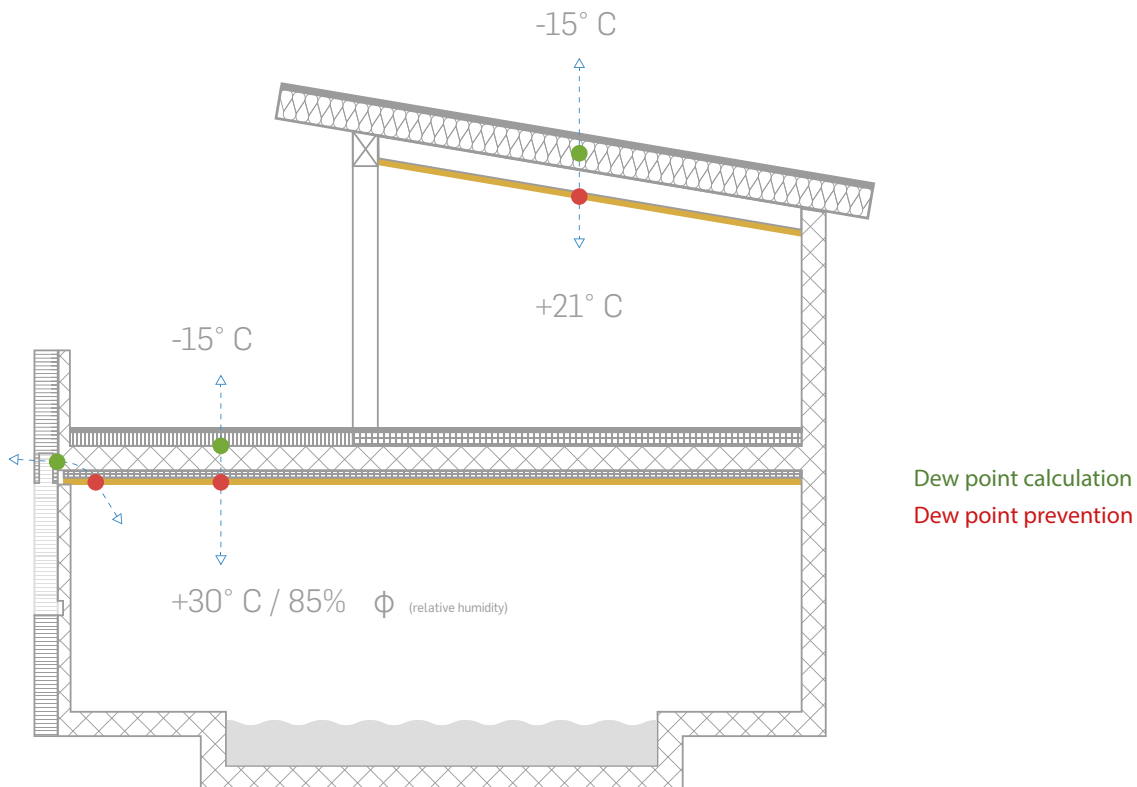

BASWA DTG Prime Base/ Fine/Top/Casual	U-value ($\text{W}/\text{m}^2 \text{K}$)	Λ Lambda-value ($\text{W}/\text{m K}$)	R-Value ($\text{m}^2 \text{K} / \text{W}$)
40 mm	approx. 1,0	approx. 0,040	1,0

BASWA Colours

The choice of colours for the BASWA coating compounds is almost unlimited. The coating compounds can be coloured in almost any desired shade. After delivery of a colour reference, a colour sample is created by BASWA. This must be confirmed by the architect or client.

In order to achieve coloured surfaces, the BASWA coating materials are dyed at the factory to order. The colour formulations are determined individually for each new colour in the BASWA acoustic AG laboratory; due to the special properties of the porous surfaces, each colour formulation is compared by eye with the original pattern.

The pigment preparations are mixed into the coating masses without further addition of additives. The coloured products are then applied on site. Furthermore, all desired colours can be mixed on order according to references of common colour cards or physical samples.

The products are made from natural marble sand. Untreated natural products are always subject to minimal colour variations and can easily influence the basic tone of the colour. The standard white of the BASWA coating dimensions corresponds approximately to NCS S 0500-N.

Due to the porosity of the surface, finished BASWA surfaces can have very different effects depending on the incidence of light. Similar to other mineral systems, a slight cloud formation cannot be excluded with coloured surfaces.



Light reflection of BASWA acoustic coatings

Light reflection on surfaces in rooms should be as high as possible, because poor lighting conditions can lead to fatigue, headaches, poor eyesight and noticeably reduced productivity at the workplace.

The BASWA acoustic coatings with white surface have an optimal light reflection between 75–79%. This enables a high level of light diffusion and thus an even distribution of light, which can considerably increase well-being. Artificial and natural light is also used efficiently and can also contribute to energy savings.

The following values refer to measurements carried out according to DIN EN ISO 11664-4 according to CIELAB system.

Coating	Light reflection	Degree of whiteness (CIE-Y value)
BASWA Base	0,75	89,61
BASWA Fine	0,77	90,28
BASWA Top	0,79	91,30
BASWA Fresh	0,76	89,66
BASWA Casual	0,76	89,85

Surface structures and effects

Surface structures and effects

The smooth finish of the BASWA DTG acoustic systems with their fine, smooth surface texture supports the design of modern, timeless architecture. Using special installation techniques, various plaster structures can be imitated, which are often used in the acoustic renovation of historic buildings.

- Spray application
- Brush Texturing
- Modeling the trowel

Sparkling effects with BASWA Shine

BASWA Shine surface refinement gives the surface a glittering effect without significantly impairing its acoustic performance. The mica dispersion BASWA Shine is used for the subsequent finishing of BASWA acoustic surfaces. It must be directly illuminated with the help of the lighting concept in order to achieve the glitter effect

On request, BASWA acoustic AG develops special surface effects in cooperation with customers.



Protection, cleaning, maintenance and refurbishment

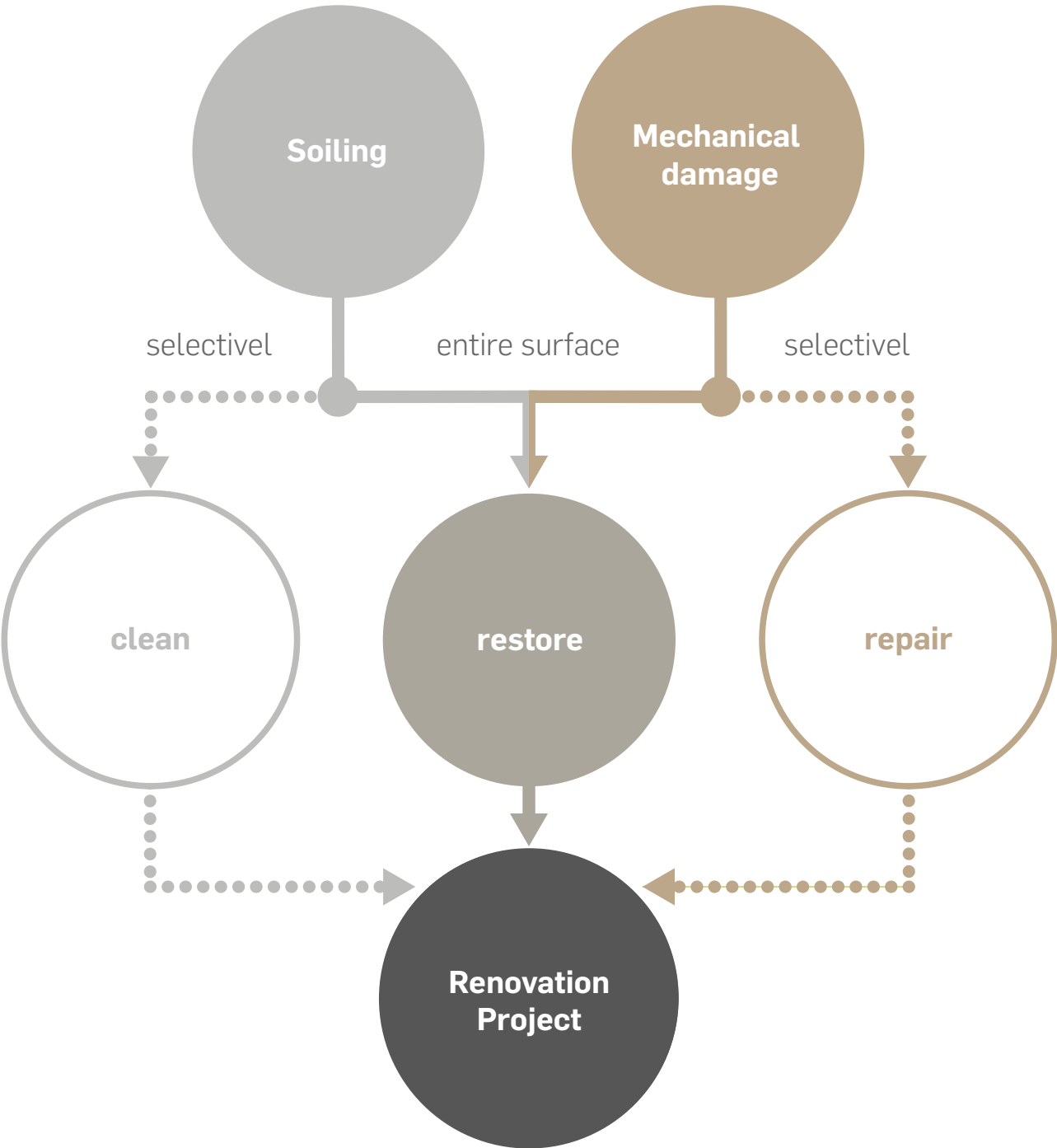

General information

BASWA acoustic systems are fine-pored surfaces that absorb sound energy. The pore size and the number of pores significantly determine the absorption properties of the various acoustic systems. In order to maintain the porosity of the surface and thus the effectiveness of sound absorption, BASWA surfaces must not be painted under any circumstances.

Aging of BASWA DTG acoustic systems

The open-pored BASWA DTG surfaces act like a filter due to their permeability to changes in air pressure. Over the years, fine dust can therefore settle in the pores, which can lead to a discreet greying of the surfaces. Under normal conditions this greying is very minimal and hardly visible. Ageing has no influence on the acoustic performance of the system.

Since the BASWA DTG acoustic systems are installed exclusively with BASWA DTG acoustic panels that are airtight on the rear side, and are airtight on the front side with BASWA Fix DTG and glued airtight on the longitudinal joints, air flow through the system is excluded. Consequently, ageing and greying of the surface take place very evenly and only very slowly.

Furthermore, the following must be observed

- No cleaning attempts with water or other cleaning agents!
- In general, only touch the surface with clean hands or wear clean gloves.
- Always protect BASWA surfaces with masking tape during connection work.
- Do not rub superficial, partial soiling (dust, fingerprints etc.), otherwise the dirt will penetrate deeper into the pores.
- Do not paint BASWA acoustic ceilings!

Surface protection

BASWA Protect is a specially developed premium impregnation system to achieve deep water repellency with optimum protection for BASWA acoustic surfaces. The acoustic performance of the treated surface is not impaired. The deep penetration of BASWA Protect into the acoustic system results in significantly lower dirt and water absorption. This prevents the immediate ingress of liquids and thus reduces the absorption capacity of liquid type dirt and dirt particles that have combined with liquids. Furthermore, the impregnation can have a positive influence on the cleaning of BASWA surfaces and the longevity of BASWA surfaces.

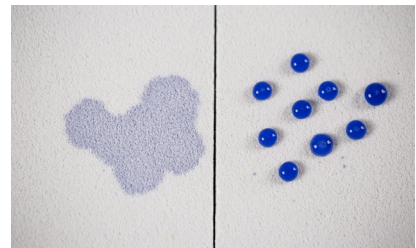

BASWA Protect (right)

Cleaning

Dry dirt or dust adhering to the surface can be removed with adhesive tape or a fine brush (attached to a suction device).

Partial organic soiling (beverage stains, grease, nicotine, etc.) can be removed with BASWA Blond (bleaching agent) or BASWA Clean (special enzyme cleaner). Prior treatment of the surfaces with BASWA Protect facilitates cleaning and maintenance work.



BASWA Clean

BASWA Fresh

The mineral dispersion technology of BASWA Fresh is used to renovate age- and use-related discolourations of BASWA surfaces. BASWA Fresh is a part of the BASWA maintenance and refurbishment product line and can therefore be combined with other applications, such as surface cleaning with BASWA Clean. Treating surfaces with BASWA Fresh, however, does not replace full renovation, but can considerably extend the service life of a BASWA surface. The professional application refreshes age-related discolourations as well as faded BASWA surfaces and gives them back their new appearance. The acoustic performance is virtually unaffected. BASWA Fresh is not suitable for re-colouring existing BASWA acoustic surfaces.

Note! With coloured BASWA acoustic surfaces treated with BASWA Fresh, colour differences in relation to the original colour cannot be ruled out. BASWA Fresh may only be used by specially trained companies (certified BASWA partners).

BASWA Fresh is supplied in as close to the original colour of the existing surface as possible.



BASWA Fresh

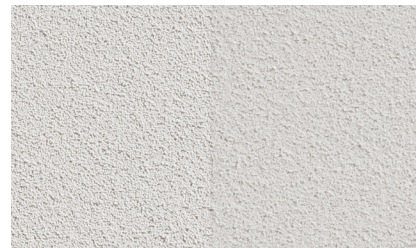

BASWA Fresh (left)

BASWA Casual

BASWA Casual is an acoustic spray plaster that is also used for the renovation of existing BASWA acoustic surfaces.

In the case of renovation, BASWA Casual is applied to the existing acoustic system in 1 to 2 work steps. This creates a slightly textured, homogeneous seamless surface.

Dirty and damaged areas or surfaces must be cleaned in advance with suitable agents (e.g. BASWA Clean) and partially repaired.

As part of a complete renewal, the BASWA coating compounds can be removed with the help of sanding equipment and then the acoustic coatings can be reapplied. Depending on the system, it is also possible to additionally apply a new final coating. In this case, however, a slight impairment of the absorption capacity must be accepted.



BASWA Casual

BASWA maintenance and renovation concept

BASWA acoustic ceilings should only be refurbished by specially trained companies.

The specialized company investigates the case and decides which measures and methods are most suitable for refurbishment. Depending on the soiling, the size of the ceiling and the available time window, various measures have to be combined for a successful renovation.

Each renovation is unique and individual in needs, this is highly considered when finding a solution for your project.

Common construction details

Common construction details

For the planning of various construction details such as surface connections, edge formations, separation and expansion joints as well as various installations, a large number of schematic detail drawings are available on our website.

The following pages describe the most important points of the most common detailed solutions by topic.

Wall connection shadow gap – PVC end profile

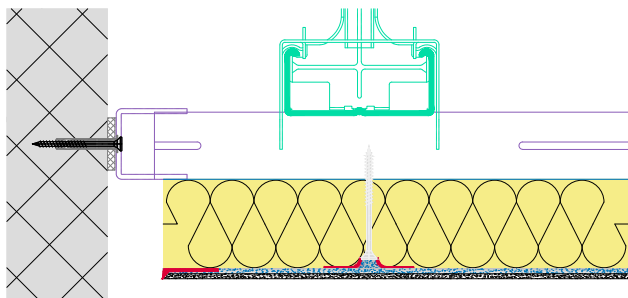

DD_002dtg – lengthwise

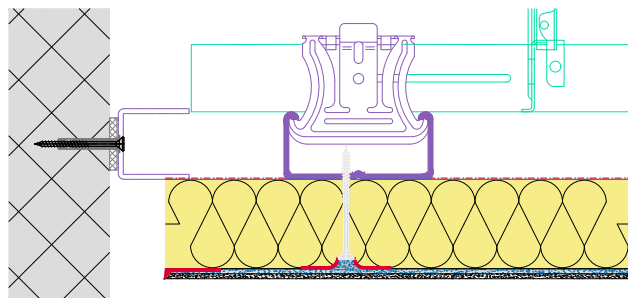

DD_002dtg – crosswise

Wall connection shadow gap – L profile

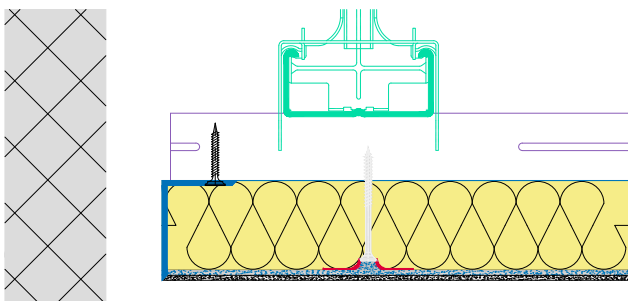

DD_003dtg – lengthwise

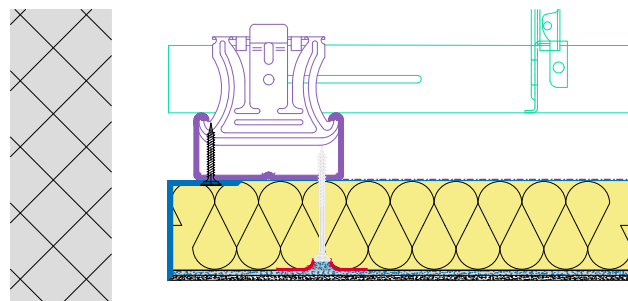

DD_003dtg – crosswise

Wall connection airtight without circumferential shadow gap (project-specific)

To prevent uncontrolled cracking, the coating compounds of all BASWA acoustic systems must be separated from adjacent surfaces and/or building structures (such as columns, wall connections, window or door frames made of metal or wood and others) with a ceiling separation strip. The connections between the wall profile and the DTG acoustic panels are sealed airtightly and flexibly with BASWA Siga Sicral!

Depending on the optical or building-physical requirements, this can be done with a paper separating strip or PE foam separating strip.

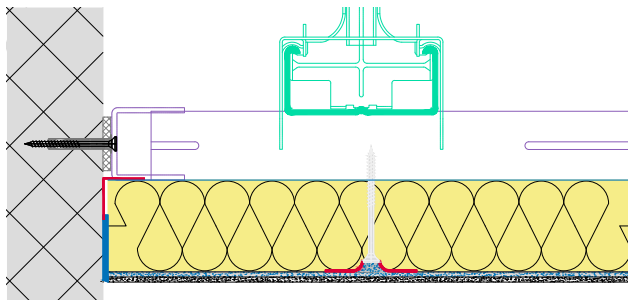

DD_004dtg – lengthwise

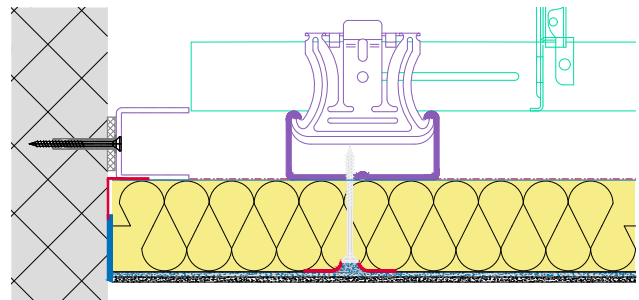

DD_004dtg – crosswise

Spotlights

For all openings for installations without BASWA installation platforms, such as light recessed luminaires like ceiling ports, the DTG panels can be carefully executed with a crown drill. All tile faces of penetrations (vertical mineral wool side) must be sealed airtight with BASWA Fix DTG, K or C and/or sealed airtight by taping with aluminium adhesive tape. This prevents partial soiling due to air flow.

Attention! With loads of max. 1.5 kg point load, the ceiling luminaires can be fixed directly to the cavity (clamp fixing). Permissible are a maximum of 2 pcs/m².

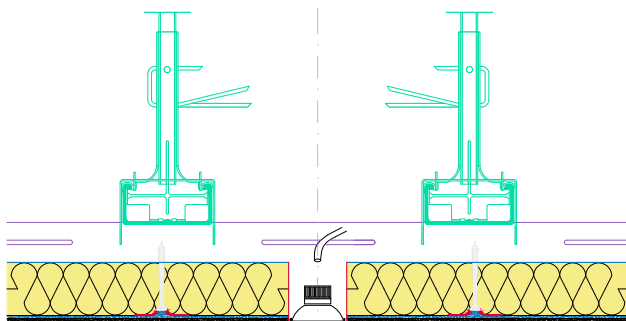

DD_010dtg – lengthwise

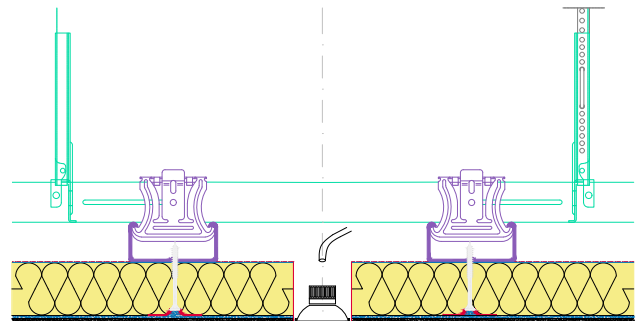

DD_010dtg – crosswise

Ceiling lights

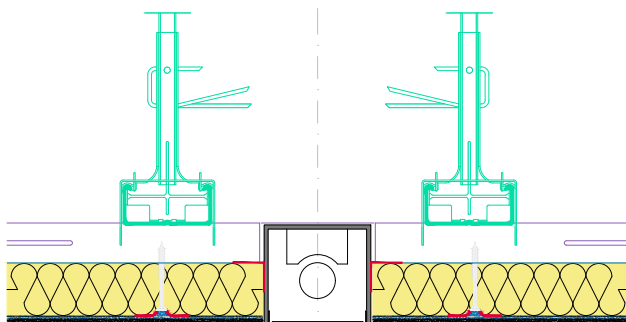

DD_011dtg – lengthwise

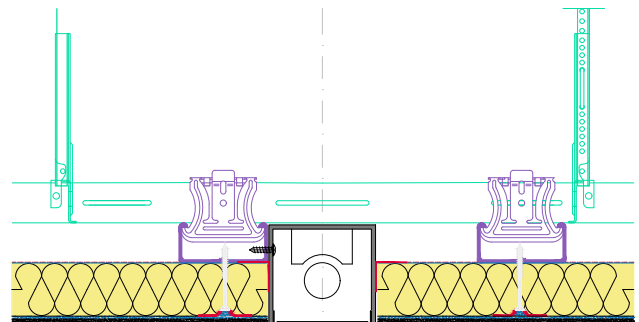

DD_011dtg – crosswise

Installations with BASWA installation platforms DTG

All installations, such as recessed lights, surveillance cameras, motion and fire detectors, loudspeaker boxes, etc. that are mechanically fixed to the substrate must be installed and fixed with BASWA installation platforms.

Installing BASWA installation platform DTG (400x400)

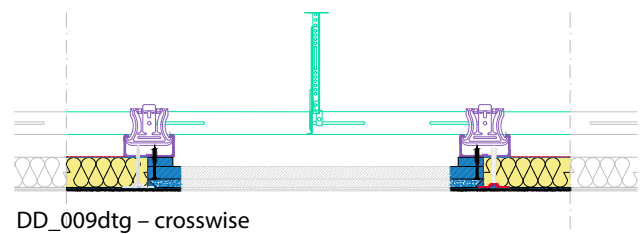
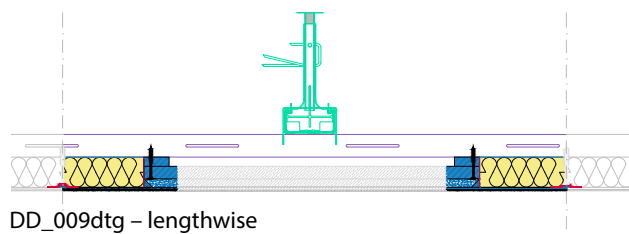

Ventilation outlet

In order to exclude or reduce partial soiling around ventilation slots, the supply and exhaust air should be directed to the side of the wall. If this is not possible, ensure that the air exchange rate is as constant and as low as possible so that no standing air vortices result. With an air discharge angle of 45 °, contamination is greatly reduced.

Ventilation ducts in the cavity behind should be sealed in the connection to the BASWA DTG system so that no additional negative pressure is created in the ceiling cavity. (Siga Sicrall recommended)

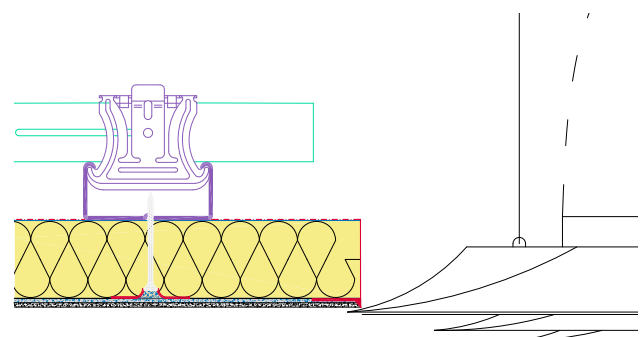
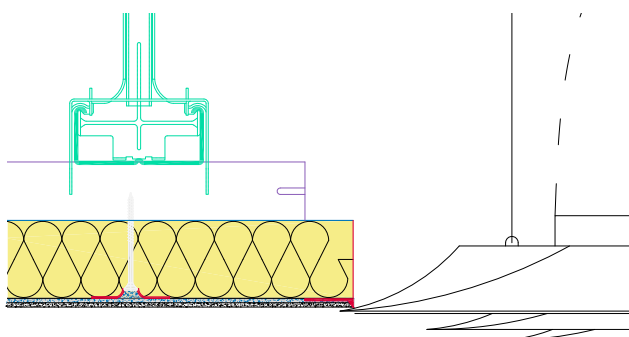

Installation BASWA access panel (service openings) with change UK Horizontal section

The BASWA inspection opening hatches are individually height-adjustable and factory RAL9010 PUR-coated. A special breathable acoustic inlay in the door frame prevents the surfaces from ageing differently. It is important that the lateral connection between the outer frame and the substructure is airtight beforehand. This prevents air from flowing through the adjacent acoustic system.

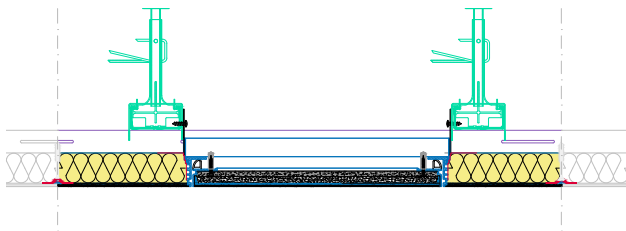

DD_008dtg – lengthwise

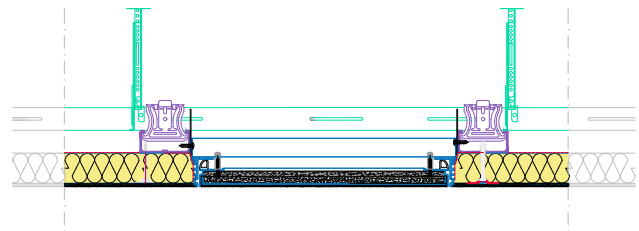

DD_008dtg – crosswise

Building expansion joints



Reference value:

- Partial surface, side length ≤ 10 m = expansion joint $b = 15$ mm
- Partial surface, side length > 10 m = expansion joint $b = 20$ mm

Execution of expansion joints with BASWA PVC end profile

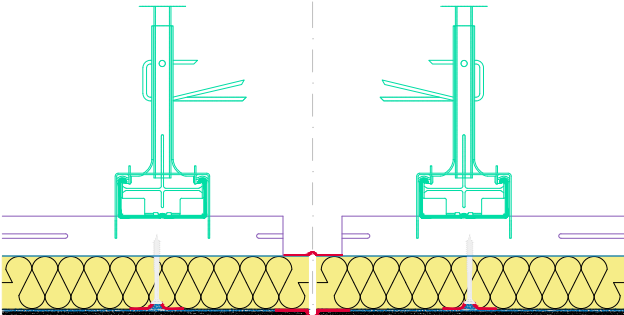

DD_006dtg – lengthwise

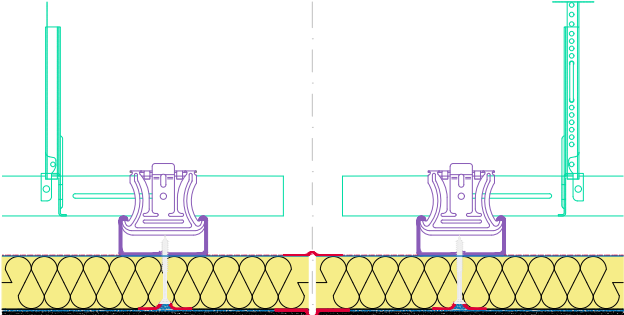

DD_006dtg – crosswise

Execution expansion joints with a 361, Profi 430 profiles

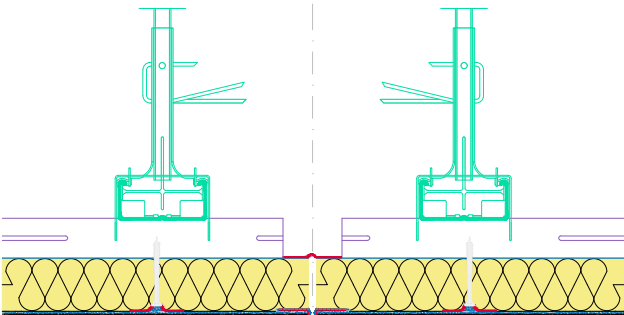

DD_005dtg – lengthwise

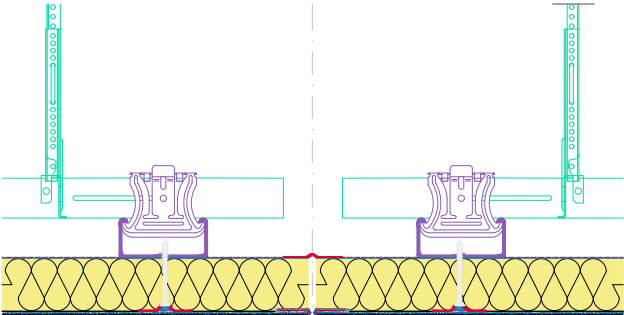

DD_005dtg – crosswise

Execution of expansion joints with PVC L angle profile

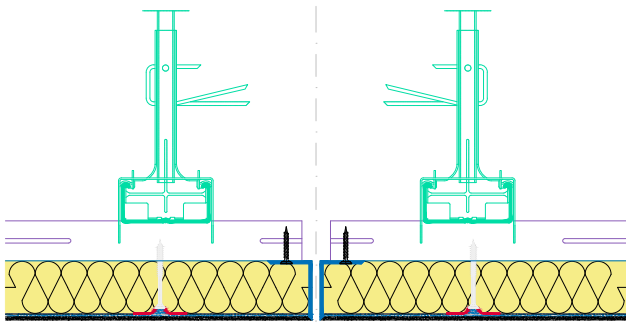

DD_007dtg - lengthwise

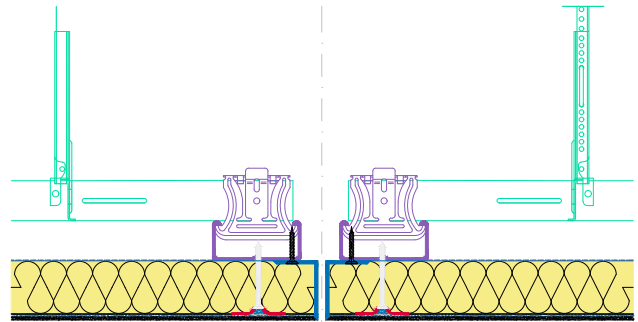

DD_007dtg - crosswise

Design outside corner 90 degrees DTG / DTG

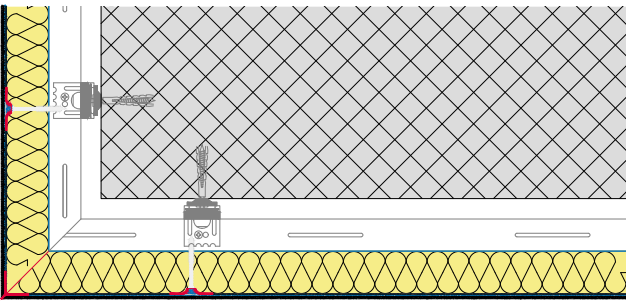

DD_012dtg - lengthwise

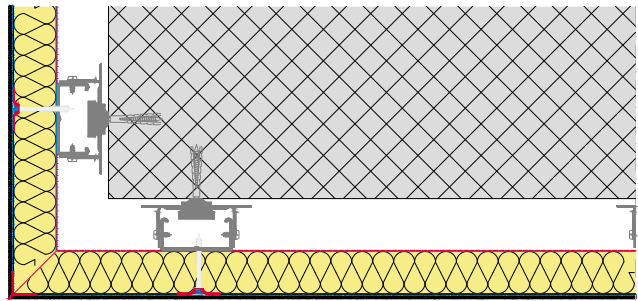

DD_012dtg - crosswise

Design outside corner 90 degrees DTG / GKB smoothed and painted

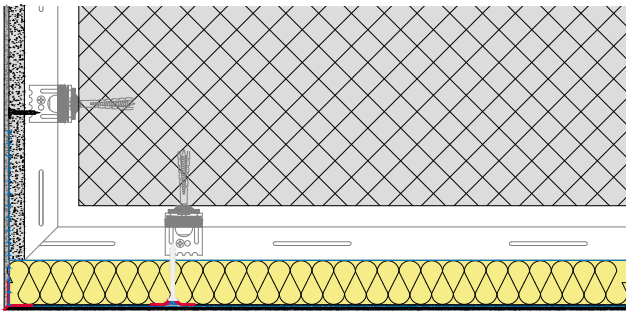

DD_013dtg - lengthwise

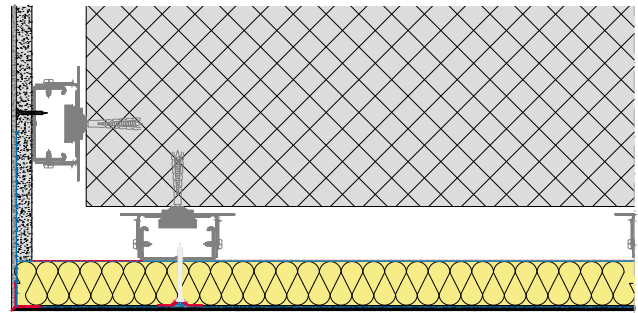

DD_013dtg - crosswise

Finish inside corner

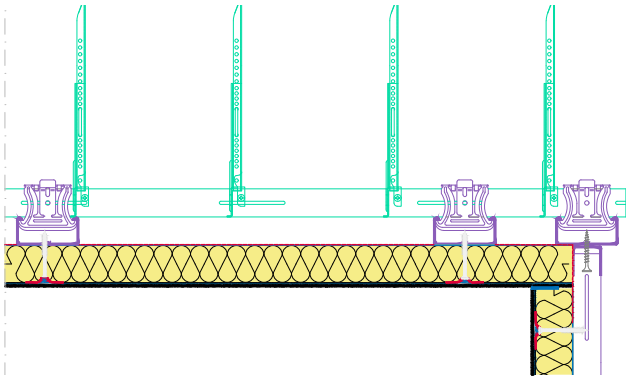

DD_014dtg



Ceiling canopy

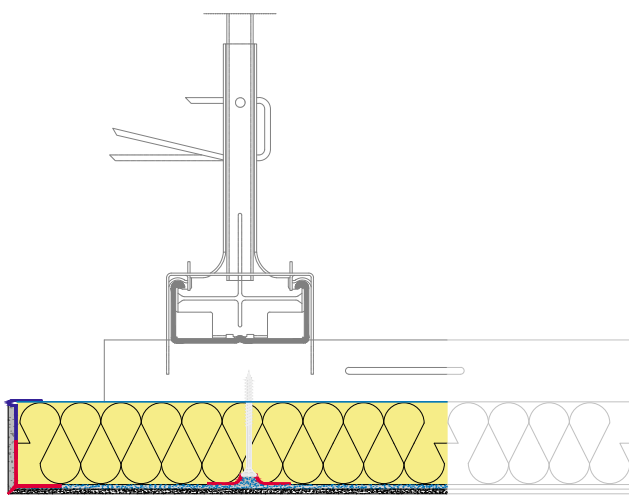

DD_015dtg – lengthwise

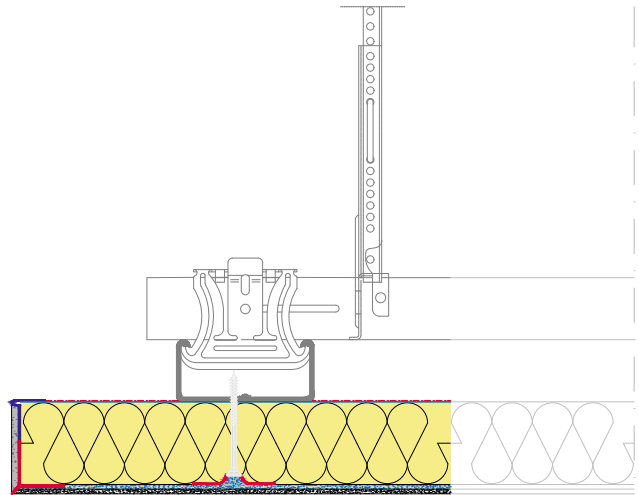

DD_015dtg – crosswise

Legal notice

The above information, in particular the suggestions for installation and use of our products, are based on our knowledge and experience in normal cases, provided that the products have been stored and used properly. Because of the different materials, substrates and different working conditions, a warranty of a work result or a liability, regardless of the legal relationship, cannot be based on these references or on verbal advice, unless we are guilty of intent or gross negligence in this respect. In doing so, the User must prove in writing that he has provided BASWA in a timely and complete manner with all the knowledge required for BASWA's proper and promising assessment. The user must test the products for their suitability for the intended application. Product specifications are subject to change without notice. The industrial property rights of third parties must be observed. In all other respects, our respective terms and conditions of sale and delivery shall apply. The most current product data sheet applies, which can be requested from us.

Planning documents for BASWA DTG acoustic systems.

The current valid version can be found online on our website www.baswa.com.

BASWA acoustic AG +41 (0)41 914 02 22 www.baswa.com

General Terms and Conditions (GTC) of BASWA acoustic AG

1. General information

These General Terms and Conditions apply to all services and deliveries of BASWA acoustic AG (hereinafter referred to as "BASWA") to the customer ("Purchaser"). Deviating conditions of the Purchaser which BASWA does not expressly accept in writing shall not be binding on BASWA. Even if BASWA does not expressly contradict these conditions.

2. Quotes

Offers from BASWA are always non-binding. Technical data, descriptions or illustrations of the delivery item in offers, brochures or other information documents do not constitute warranted characteristics and are subject to BASWA's right of modification. The indication of average consumption values of BASWA products is without guarantee. Quantity calculations prepared by BASWA (material excerpts) shall be checked immediately by the Employer and shall be made without warranty. Contracts with BASWA shall not be concluded until BASWA has confirmed the order in writing, but in any case upon delivery. The content of the contract shall be governed by BASWA's order confirmation or, in the absence thereof, by BASWA's quotation. BASWA reserves the right to make technical, constructive and design changes, in particular improvements, even after order confirmation, insofar as this is reasonable for the Customer.

3. Prices

Unless otherwise agreed, all prices are quoted without value added tax in Swiss francs, including packaging. The price calculation shall be based on the prices valid on the day of delivery, unless otherwise agreed in writing. The prices apply in Switzerland free truck-accessible construction site (Incoterms 2010 CPT Carriage paid to); unloading is carried out by the customer. Deliveries are made on Euro pallets. These will be invoiced at CHF 15.00 per pallet. Euro pallets can be returned. These are credited for the same amount, as long as they can be used again after being returned to BASWA. Defective pallets will not be reimbursed. Outside Switzerland, the terms of delivery FCA (Free carrier) according to Incoterms 2010 apply.

4. Terms of payment

Unless otherwise agreed, all invoices are due for payment net within thirty days of the invoice date. If payment is made after the due date, BASWA shall be entitled to charge default interest of 6% per annum. Offsetting against BASWA's claims shall only be permissible if the Customer's counterclaim has been acknowledged in writing or has been legally established. The goods shall remain the property of BASWA until full payment has been made.

5. Delivery dates

The delivery periods notified by BASWA are carefully determined, but are not binding. If dispatch is delayed for reasons for which BASWA is not responsible, the delivery period shall be deemed to have been observed if notification of readiness for dispatch has been given within the agreed period. If delivery becomes impossible in whole or in part due to force majeure or difficulties through no fault of BASWA's own, BASWA shall be entitled to withdraw from the contract. The same applies if such circumstances occur with subcontractors or suppliers. In this case, the customer has no claim to compensation or subsequent delivery.

6. Delivery

Deliveries with a goods value of less than CHF 500 are subject to a freight surcharge in Switzerland. Unloading on site. Special transports will be invoiced to the customer. Outside Switzerland, the terms of delivery FCA (Free carrier) according to Incoterms 2010 apply.

7. Risk assumption

The customer bears the risk for all deliveries, including any returns. The risk shall pass to the Customer as soon as the consignment leaves BASWA's warehouse or a third party warehouse maintained by BASWA. If the shipment is carried out at the request of the purchaser or for reasons for which the purchaser is responsible.

In the event of a delay in delivery due to circumstances beyond our control, the risk shall pass to the Purchaser from the date of notification of readiness for dispatch for the duration of the delay. The shipper is responsible for ensuring that the goods are properly packed and shipped. Goods that arrive at BASWA after the expiration date or are defective will not be refunded.

8. Complaints, Warranty

Warranty for defects, with the exception of the designated properties of the products according to the BASWA article list, is excluded. For special solutions (i.e. for products that are not on the BASWA article list) and colored coating compounds, any warranty is excluded. Color differences due to raw materials are not considered defects. Any liability is excluded in the event of improper use of BASWA products in combination with other or third-party systems, products or technologies. The delivery is to be checked immediately. Complaints due to incomplete, incorrect or defective delivery must be reported immediately after delivery, at the latest however after three days (72 hours). BASWA shall be liable for defects within the meaning of the preceding paragraph in accordance with the following provisions:

Unless otherwise agreed in writing, the warranty period for the warranted properties of the products shall be based on the corresponding expiry date. The customer shall in all cases comply with the contractual obligations incumbent upon him, in particular the agreed terms of payment. BASWA shall have the right to replace the defective goods by a subsequent delivery. A cancellation of the contract by the customer is excluded. In the event of improper storage and/or non-compliance with the processing guidelines specified by BASWA by the Customer or a third party, any warranty and liability shall be excluded if the Customer or a third party violates their own diligence as craftsmen. Further claims of the Purchaser against BASWA or its vicarious agents shall be excluded, in particular claims for compensation for damage not caused to the delivery item itself.

Claims for damages are limited to the amount of the purchase price.

9. Returns

BASWA is not obliged to accept returns and to reimburse them. In exceptional cases, however, this is possible in the original condition without a wall. The remuneration for accepted returns is 90% of the value of the goods minus deduction for transport costs. Colored products are neither taken back nor reimbursed.

10. Liability

Unless expressly stated otherwise in these terms and conditions, BASWA shall only be liable for damages caused by it intentionally or through gross negligence. Any liability for auxiliary persons of BASWA is hereby expressly excluded.

11. Place of performance

The place of performance shall be the registered office of BASWA.

12. Place of jurisdiction

The exclusive place of jurisdiction for all disputes arising in connection with these General Terms and Conditions as well as the contracts concluded within the framework of these Terms and Conditions **shall be the domicile of BASWA**. BASWA shall be entitled to bring an action before any court having jurisdiction over the Customer.

13. Applicable law

These general terms and conditions as well as the contracts concluded within the framework of these conditions are subject to Swiss law. Processing guidelines of BASWA are part of the General Terms and Conditions. The application of the provisions of the United Nations Convention on Contracts for the International Sale of Goods of 11 April 1980 (Vienna Sales Convention) is excluded.

Baldegg, December, 2017

